

ICC-ES Evaluation Report

ESR-1295

Reissued February 1, 2011

This report is subject to re-examination in two years.

www.icc-es.org | (800) 423-6587 | (562) 699-0543

A Subsidiary of the International Code Council®

**DIVISION: 06 00 00—WOOD, PLASTICS AND
COMPOSITES**
Section: 06 12 00—Structural Panels
REPORT HOLDER:
**INSULSPAN INCORPORATED
100, 2886 SUNRIDGE WAY NE
CALGARY, ALBERTA T1Y 7H9
CANADA**
www.insulspan.com
jwhalen@insulspan.com
EVALUATION SUBJECT:
**INSULSPAN STRUCTURAL INSULATING PANEL
SYSTEM**
1.0 EVALUATION SCOPE
Compliance with the following codes:

- 2006 *International Building Code*® (IBC)
- 2006 *International Residential Code* (IRC)

Properties evaluated:

- Structural
- Fire resistance

2.0 USES

The Insulspan Structural Insulating Panel System consists of structural insulated roof and floor panels, and load-bearing or nonload-bearing wall panels for Type V construction. The panels are alternatives to walls, floors and roofs designed in accordance with IBC Section 2306. Panels used in one-hour fire-resistance rated assemblies must be installed in accordance with Section 4.2.4.

When panels are installed under the IRC, an engineered design is required in accordance with IRC Section R301.1.3.

3.0 DESCRIPTION
3.1 General:

Insulspan Structural Insulating Panels are factory-assembled, laminated sandwich panels produced at locations listed in Table 1 of this report. The panels consist of expanded polystyrene (EPS) foam plastic cores with wood-based structural-use sheathing facings. The panels are manufactured in two configurations as noted in Section 3.1.1 and 3.1.2.

3.1.1 OSB Surface Spline or Insulspline Panels:

These types of panels are produced in widths ranging from 4 feet (1219 mm) to 8 feet (2438 mm), and lengths ranging

from 8 feet (2438 mm) to 24 feet (7315 mm). The core of these panel types is recessed on the ends to receive 2-inch (nominal thickness) solid sawn dimensional lumber sized to match the thickness of the panel core. The core is recessed along the longitudinal edges to receive either two 3-inch-wide-by-⁷/₁₆-inch-thick (76 mm by 11.1 mm) OSB surface splines, or one 3-inch wide (76mm) Insulspline spline having a thickness to match the thickness of the sandwich panel core. (See Section 3.2.4 for a description of the splines.) See Figure 1 for illustrations of these panel types.

3.1.2 Dimensional Lumber Spline Panel: This type of panel is produced in maximum 4-foot (1219 mm) widths and lengths up to 24 feet (7315 mm). The EPS core of this panel type is recessed along the longitudinal edges and ends to receive nominally 2-by solid sawn dimensional lumber sized to match the core thickness of the panel. See Figure 1 for additional information on this panel type.

3.2 Materials:

3.2.1 Core: The core material is Type I expanded polystyrene (EPS) foam plastic with nominal thicknesses ranging from 3¹/₂ inches (89 mm) to 11¹/₄ inches (285 mm). The EPS is a Type I expanded polystyrene with a nominal density of 1 pcf (16 kg/m³), complying with ASTM C 578. The EPS has a flame spread index of not more than 75 and a smoke developed index of not more than 450 when tested in accordance with ASTM E 84. The EPS is supplied by manufacturers having ICC-ES evaluation reports, who are listed in the ICC-ES approved Insulspan quality control documentation.

3.2.2 Facing: Panel facing material is ⁷/₁₆-inch-thick (11.1 mm), Exposure 1, oriented strand board (OSB) with a span rating of 24/16, and complying with the performance-rated panel requirements specified in U.S. Department of Commerce Product Standard PS-2. The OSB is supplied by manufacturers listed in the ICC-ES approved quality control documentation.

3.2.3 Adhesive: The adhesive is a Type II, Class 2, laminating adhesive as specified in the ICC-ES approved quality control documentation. The adhesive complies with the ICC-ES Acceptance Criteria for Sandwich Panel Adhesives (AC05).

3.2.4 Splines: There are three types of splines: OSB surface splines, Insulsplines and solid sawn dimensional lumber. OSB surface splines are 3-inch-wide-by-⁷/₁₆-inch-thick (76 by 11.1 mm) OSB, as described in Section 3.2.2, that are installed into recesses in the panel core, along the longitudinal edges of the panels, behind the panel facers on both faces of the panels. Insulsplines are 3-inch-wide (76 mm) sections of Insulspan sandwich panels manufactured with a total thickness to match the core

thickness of the sandwich panel for which the Insulspline is to be used. The dimensional lumber splines are nominally 2-by, No. 2 spruce-pine-fir, or better, dimensional lumber members sized in depth to match the core thickness, unless noted otherwise in this evaluation report.

4.0 DESIGN AND INSTALLATION

4.1 Design:

The allowable uniform transverse load, uniform axial compression load for bearing walls and axial compression concentrated load for bearing walls are as shown in Tables 2 through 8. Unless noted otherwise, the allowable uniform transverse loads are for panels installed under simply supported, single span conditions.

The allowable racking shear loads in Tables 9 and 10 are applicable to the panels used as shearwalls in Seismic Design Categories A, B and C. For panels installed and supported directly by a concrete foundation, the allowable racking shear values for Configurations A and C of Table 9 and Configurations A and B of Table 10, are also applicable to shearwalls in Seismic Design Categories D, E and F, provided the panels are limited to use as nonload-bearing walls. Panels, installed and supported directly by a concrete foundation in Configuration C of Table 9 and Configuration B of Table 10, can also be used as bearing walls, provided the panels are a maximum of 4 feet wide with lumber splines at 4 feet on center designed to support gravity loads, and a horizontal top member installed that is designed to support gravity loads in distributing the loads to the lumber splines.

The seismic-force-resisting system consisting of the sandwich panel shearwalls, in whole or in part, shall be designed and detailed in accordance with Sections 2305 and 2306 of the IBC by the registered design professional.

Where loading conditions result in the panels resisting combined loads, the sum of the ratios of applied loads over allowable loads must be less than 1.0.

4.2 Installation:

4.2.1 General: The panels must be installed in accordance with the manufacturer's published installation instructions and this report. A copy of the installation instructions must be available at all times on the jobsite during installation. Panel locations must comply with the report and the plans and specifications approved by the code official.

The panels must be connected to each other along their edges with the splines described in Section 3.2.4, as specified by the applicable tables in this report. Unless noted otherwise in this report, OSB facings of the panels must be attached to the splines with 8d box nails, or equivalent, spaced at a maximum of 6 inches (152 mm) on center.

Top and bottom plates installed into the recessed core of the ends of the wall panels must be dimensional lumber, sized to match the core thickness, and fastened to both panel facings with 8d box nails, or equivalent, spaced at a maximum of 6 inches (152 mm) on center, unless noted otherwise in this evaluation report.

Wall openings must be framed with conventional materials, designed to the satisfaction of the code official.

The wall panels used as bearing walls must be installed in the manner described in the footnotes in Tables 6 through 8.

Unless noted otherwise in this report, an EPS-compatible sealant is applied along butting EPS core surfaces and any dimensional lumber surfaces, and along the bottom of the

panel base plate before panel placement. Typical installation details are shown in Figures 1 through 6. Structural calculations must be prepared to substantiate the details for the specific installation and loading conditions.

4.2.2 Thermal Barrier:

4.2.2.1 Wall, Roof and Floor: One-half-inch-thick (12.7 mm), regular gypsum wallboard, complying with ASTM C 36 or ASTM C 1396, must be installed on the interior surface of wall and roof panels, and the bottom side of floor panels having occupied space below the floor panel. The wallboard must be fastened to the face of the panels with minimum 1¹/₄-inch-long (31.7 mm), No. 6, Type W drywall screws spaced in accordance with ASTM C 840 for use under the IBC, or Table R702.3.5 of the IRC, using 16-inch-on-center (406.4 mm) framing spacing guidelines.

4.2.2.2 Floor: An approved thermal barrier must be installed over the top surface of the floor panels, such as minimum 7¹/₁₆-inch-thick (76 mm) wood-based structural-use sheathing installed in accordance with the applicable code.

4.2.3 Panel Cladding:

4.2.3.1 Roof Covering: The roof covering must comply with Chapter 15 of the IBC, or IRC Section R901, as applicable. Roofs with hot-asphalt or hot-coal tar pitch are prohibited. Underlayment and flashing must be installed in accordance with the applicable code.

4.2.3.2 Exterior Wall Covering: The exterior face of wall panels is required to be covered with a wall covering complying with the applicable code or recognized in a current ICC-ES evaluation report. A water-resistive barrier must be installed over the panels in accordance with IBC Section 1404.2 or IRC Section R703.2, as applicable, prior to application of the wall covering. Where portland cement plaster is used, compliance with IBC Section 2510 and 2512 or IRC Section R703.6.3, as applicable, is necessary.

All exterior panel joints must be sealed with a compatible acrylic latex caulk before covering.

4.2.4 One-hour Fire-resistance-rated Limited Load-bearing Wall: Walls constructed with the 6¹/₂-inch-thick (165 mm), dimensional lumber spline panels, described in Section 3.1.2, with double lumber splines and covered with two layers of 5¹/₈-inch-thick (15.9 mm), Type X gypsum wallboard on both faces of interior walls, or two layers of 5¹/₈-inch-thick (15.9 mm) Type X wallboard on the interior face of exterior walls and two layers of 5¹/₈-inch-thick (15.9 mm) Type X gypsum sheathing on the exterior face of exterior walls, are one-hour fire-resistance-rated limited load-bearing walls when installed in accordance with this section of this report. Panels with the two layers of gypsum wallboard on only the interior face of exterior walls are rated for exposure to fire on the side of the wall with the gypsum wallboard (interior face) and are subject to the limitations noted in IBC Section 704.5. The maximum allowable axial load is 91 percent of the allowable axial load noted in Table 7 for panels with a 6¹/₂-inch (16.5 mm) thickness, or 2,400 plf (35.0 kN/m), whichever is less. The EPS core of the panels must be recessed at the top and bottom of the panel for the installation of nominally 2-by spruce-pine-fir lumber top and bottom plates sized to match the panel's core thickness. Double 2-by No. 2 spruce-pine-fir wood splines must be installed in the vertical panel edges spaced a maximum of 48-inches (1219 mm) on center. The OSB facings of the panels must be secured to the top plate, bottom plate and splines with 8d common nails spaced at 4 inches (102 mm) on center. The 5¹/₈-inch-thick-by-4-foot-wide (15.9 mm by 1219 mm),

Type X gypsum wallboard must be applied vertically in two layers. The first layer must be installed without horizontal joints and with vertical edges aligned over the center of the vertical splines of the sandwich panels. The first layer of Type X gypsum wallboard must be attached with 2¹/₂-inch long (63.5 mm), No. 6, Type W wallboard screws spaced at 8 inches (203 mm) on center, 1 inch (25.7 mm) from the gypsum wallboard edges and ends. The field area of the gypsum wallboard must be secured with 1¹/₄-inch-long (31.7 mm), No. 6, Type W wallboard screws spaced at 16 inches (406 mm) on center both horizontally and vertically. The second layer of Type X gypsum wallboard must be installed without horizontal joints, and with the vertical edges offset 24 inches (610 mm) from the first layer joints. The second layer must be attached with 2¹/₂-inch long (63.5 mm), No. 6, Type W wallboard screws spaced at 8 inches on center, 1¹/₂ inches (38 mm) from the gypsum wallboard edges and ends, and spaced at 16 inches (406 mm) on center both horizontally and vertically in the field of the gypsum wallboard. The joints of the second layer of gypsum wallboard must be covered with joint tape and compound in accordance with ASTM C 840 or GA-216. Screw heads on the second layer of gypsum wallboard must be covered with joint compound in accordance with ASTM C 840 or GA-216.

4.3 Special Inspection:

Periodic special inspections shall be as required by IBC Section 1707.3.

5.0 CONDITIONS OF USE

The Insulspan Structural Insulating Panel System described in this report complies with, or is a suitable alternative to what is specified in, those codes listed in Section 1.0 of this report, subject to the following conditions:

- 5.1 The panels must be fabricated, identified and installed in accordance with this report and the manufacturer's published installation instructions. In the event of a conflict between this report and the manufacturer's published installation instructions, the more restrictive governs.
- 5.2 Design loads to be resisted by the panels must be determined in accordance with the applicable code, and must be equal to, or less than, the values given in Tables 2 through 10 of this report.
- 5.3 All construction documents specifying the building panels described in this report must comply with the design limitations of this report. Design calculations and details for the specific applications must be furnished to the code official verifying compliance with this report and applicable codes. The documents must be prepared by a registered design professional where required by the statutes of the jurisdiction in which the project is to be constructed.
- 5.4 All floor-to-wall and roof-to-wall details must be designed such that gravity loads are applied to the wall panels as described in the footnotes to Tables 6 through 8.
- 5.5 Connection and attachments of the panel are outside the scope of this report and must be addressed in the design calculations and details.
- 5.6 When used as shear walls under the IBC or IRC, the panels are recognized for use in Seismic Design Categories A, B and C, except as provided for in Section 4.1. Use of the sandwich panel shear walls in Seismic Design Categories D, E and F in combination with other types of lateral force-resisting systems is outside the scope of this report.
- 5.7 Special inspections shall be as required in Section 4.3.
- 5.8 The foam plastic insulation of the panels must be separated from the interior of the building with a thermal barrier, installed in accordance with Section 4.2.2 of this report.
- 5.9 Use of the floor panels is limited to residential occupancies.
- 5.10 Use of the panels is limited to Type V construction.
- 5.11 Use of the foam plastic in areas subject to damage from termites must be in accordance with IBC Section 2603.8 and IRC Section R320.5.
- 5.12 The panels must be installed such that the panel facings are protected against decay and termites in accordance with IBC Sections 2304.11.2.2 and 2304.11.2.6, or IRC Sections R319 and R320, as applicable.
- 5.13 The panels and their attachments must be subject to inspection by the code official prior to covering with an approved water-resistive barrier or roof covering.
- 5.14 For installations of the roof panels, justification must be submitted to the code official demonstrating that the panels with the roof covering comply as a Class A, B, or C roof assembly, as required by IBC Section 2603.6, with the classification complying with the minimum classification requirements of the building.
- 5.15 The panels are produced at the Blissfield, Michigan, and Delta, British Columbia manufacturing facilities noted in Table 1, under a quality control program with inspections of both facilities by Intertek Testing Services NA Ltd., of Mississauga, Ontario, Canada (AA-691).

6.0 EVIDENCE SUBMITTED

- 6.1 Data in accordance with the ICC-ES Acceptance Criteria for Sandwich Panels (AC04), dated October 2009.
- 6.2 Reports of tests conducted in accordance with ASTM E 119.
- 6.3 Report of a room corner fire test conducted in accordance with NFPA 286.

7.0 IDENTIFICATION

The panels must have a label containing the name and address of the sandwich panel manufacturer (as noted in Table 1), the product panel number, the evaluation report number (ESR-1295) and the name of the inspection agency (Intertek Testing Services NA Ltd.). Bundles of Insulspan splines are delivered to the jobsite with shipping documents from the sandwich panel manufacturers noted in Table 1.

TABLE 1—MANUFACTURING LOCATIONS

INSULSPAN MANUFACTURING PLANTS	PLANT IDENTIFICATION NUMBER
Insulspan Incorporated 245 N. Jipson Street Blissfield, MI 49228-1167	81
Insulspan, Division of Plasti-Fab Ltd. Unit 1, 600 Chester Road Annacis Business Park Delta, British Columbia V3M 5Y3 Canada	80

TABLE 2—ALLOWABLE UNIFORM TRANSVERSE LOADS FOR FACE SUPPORTED PANELS WITH INSULSPLINES OR OSB SURFACE SPLINES (psf)^{1,2,3,4}

THICKNESS (inches)		DEFLECTION LIMITS	PANEL SPAN (feet)														
Panel	Core		4	5	6	7	8	9	10	11	12	13	14	15	16	17	18
4 ^{1/2} ⁵	3 ^{5/8}	L/180	121	97	81	68	56	47	39	32	27	—	—	—	—	—	—
		L/240	121	97	81	64	50	39	32	26	21	—	—	—	—	—	—
		L/360	101	73	55	42	33	26	21	17	14	—	—	—	—	—	—
6 ^{1/2}	5 ^{5/8}	L/180	136	109	91	78	68	60	54	46	39	—	—	—	—	—	—
		L/240	136	109	91	78	68	60	52	43	36	—	—	—	—	—	—
		L/360	136	109	84	66	53	43	35	29	24	—	—	—	—	—	—
8 ^{1/4} ⁶	7 ^{3/8}	L/180	151	120	100	86	75	67	60	55	50	44	38	33	29	26	23
		L/240	151	120	100	86	75	67	60	55	50	44	38	33	29	25	22
		L/360	151	120	100	86	73	60	50	42	36	30	26	22	19	17	15
10 ^{1/4} ⁶	9 ^{3/8}	L/180	159	127	106	91	79	71	63	58	53	49	43	37	33	29	26
		L/240	159	127	106	91	79	71	63	58	53	49	43	37	33	29	26
		L/360	159	127	106	91	79	71	63	58	51	44	38	33	29	26	23
12 ^{1/4}	11 ^{3/8}	L/180	167	134	111	95	83	74	67	61	56	51	48	43	37	33	30
		L/240	167	134	111	95	83	74	67	61	56	51	48	43	37	33	30
		L/360	167	134	111	95	83	74	67	61	56	51	48	43	37	33	30

For SI: 1 inch = 25.4 mm, 1 foot = 304.8 mm, 1 psf = 47.9 Pa.

¹The tabulated values are for panels with single span simply supported conditions with the panels supported each end on minimum 1^{1/2}-inch wide continuous supports in contact with the face of the panels, such as roof and floor panels.

²Tabulated values are applicable to panels installed with either the Insulsplines or OSB surface splines described in Section 3.1.1 installed at the longitudinal panel joints.

³Tabulated values are applicable to panels installed with the strong axis of the OSB panel facers parallel to the panel span.

⁴Values printed in italics are based on panel strength rather than stiffness.

⁵The 4^{1/2}-inch thick roof panels, having a minimum width of 4 feet, subject to concentrated roof maintenance live loads must be limited to a maximum span of 8 feet.

⁶The 8^{1/4}-inch and 10^{1/4} inch thick roof panels, having a minimum width of 4 feet, subject to concentrated roof maintenance live loads must be limited to a maximum span of 16 feet.

TABLE 3—ALLOWABLE UNIFORM TRANSVERSE LOADS FOR END SUPPORTED PANELS WITH INSULSPLINES OR OSB SURFACE SPLINES (psf)^{1,2,3,4}

THICKNESS (inches)		DEFLECTION LIMITS	Panel Span (feet)										
Panel	Core		8	9	10	11	12	13	14	15	16	17	18
4 ¹ / ₂	3 ⁵ / ₈	L/180	25	22	20	18	17	—	—	—	—	—	—
		L/240	25	22	20	18	17	—	—	—	—	—	—
		L/360	22	19	17	15	14	—	—	—	—	—	—
6 ¹ / ₂	5 ⁵ / ₈	L/180	35	31	28	25	23	—	—	—	—	—	—
		L/240	35	31	28	25	23	—	—	—	—	—	—
		L/360	35	31	28	25	23	—	—	—	—	—	—
8 ¹ / ₄	7 ³ / ₈	L/180	44	39	35	32	29	27	25	23	22	21	19
		L/240	44	39	35	32	29	27	25	23	22	21	19
		L/360	44	39	35	32	29	27	25	22	19	17	15
10 ¹ / ₄	9 ³ / ₈	L/180	49	43	39	35	32	30	28	26	24	23	22
		L/240	49	43	39	35	32	30	28	26	24	23	22
		L/360	49	43	39	35	32	30	28	26	24	23	22

For **SI**: 1 inch = 25.4 mm, 1 foot = 304.8 mm, 1 psf = 47.9 Pa.

¹The tabulated values are for panels with single span simply supported conditions with the panels supported each end by lumber plates installed in the core recesses each end of the panel, such as wall panels. The design of the lumber plate connection to the structure must be justified to the satisfaction of the code official. The lumber plates must be 2-inch nominal width, No. 2 Spruce-pine-fir, or better, for 2 x 4 and 2 x 6 plates and No. 2 Hem-Fir, or better, for 2 x 8 and 2 x 10 plates. The OSB panel facers must be attached to the lumber plates as described in Section 4.2.1.

²Tabulated values are applicable to panels installed with either the Insulsplines or OSB surface splines described in Section 3.1.1 installed at the longitudinal panel joints.

³Values tabulated for an 8 foot span length are applicable to panels installed with the strong axis of the OSB panel facer oriented either parallel or perpendicular to the panel span. The OSB panel facer strong axis must be oriented parallel to the panel span for all other span lengths.

⁴Values printed in italics are based on average peak loads divided by 3.

TABLE 4—ALLOWABLE UNIFORM TRANSVERSE LOADS FOR FACE SUPPORTED PANELS WITH DIMENSIONAL LUMBER SPLINES (psf)^{1,2,3}

THICKNESS (inches)		DEFLECTION LIMITS	PANEL SPAN (feet)																
Panel	Core		4	5	6	7	8	9	10	11	12	13	14	15	16	17	18	19	20
4 ¹ / ₂ ⁴	3 ⁵ / ₈	L/180	189	142	110	87	70	57	47	39	32	27	23	—	—	—	—	—	—
		L/240	142	106	82	65	52	42	35	29	24	20	17	—	—	—	—	—	—
		L/360	94	71	55	43	35	28	23	19	16	14	12	—	—	—	—	—	—
6 ¹ / ₂ ⁵	5 ⁵ / ₈	L/180	248	199	165	142	124	110	99	89	74	62	52	44	37	32	28	24	21
		L/240	248	199	165	142	124	101	82	67	55	46	39	33	28	24	21	18	16
		L/360	246	181	138	107	84	67	54	45	37	31	26	22	19	16	14	12	11
8 ¹ / ₄ ⁶	7 ³ / ₈	L/180	267	214	178	153	134	119	107	97	89	78	67	58	51	45	41	36	33
		L/240	267	214	178	153	134	119	107	97	86	71	60	51	43	37	32	28	25
		L/360	267	214	178	153	130	104	84	69	57	48	40	34	29	25	21	19	16
10 ¹ / ₄	9 ³ / ₈	L/180	295	236	196	168	147	131	118	107	98	90	78	68	59	53	47	42	38
		L/240	295	236	196	168	147	131	118	107	98	90	78	68	59	53	47	42	38
		L/360	295	236	196	168	147	131	118	100	85	72	61	53	45	39	34	30	27
12 ¹ / ₄	11 ³ / ₈	L/180	322	258	215	184	161	143	129	117	107	99	91	79	69	61	55	49	44
		L/240	322	258	215	184	161	143	129	117	107	99	91	79	69	61	55	49	44
		L/360	322	258	215	184	161	143	129	117	107	98	85	74	64	56	50	44	39

For **SI**: 1 inch = 25.4 mm, 1 foot = 304.8 mm, 1 psf = 47.9 Pa.

¹The tabulated values are for panels with single span simply supported conditions, with the panels supported each end on minimum 1¹/₂-inch wide continuous supports in contact with the face of the panels, such as roof and floor panels.

²The tabulated values are applicable to panels installed with the strong axis of the OSB panel facer parallel to the panel span, and with the dimensional lumber splines described in Section 3.2.4 installed at 4 feet on center, parallel to the panel span. The 2 x 4 and 2 x 6 splines must be No. 2 spruce-pine-fir, or better, and the 2 x 8, 2 x 10 and 2 x 12 splines must be No. 2 hem fir, or better. The OSB panel facers must be attached to the splines as described in Section 4.2.1.

³Values printed in italics are based on average peak loads divided by 3.

⁴The 4¹/₂-inch thick roof panels, subject to concentrated roof maintenance live loads must be limited to a maximum span of 8 feet.

⁵The 6¹/₂-inch thick roof panels, subject to concentrated roof maintenance live loads must be limited to a maximum span of 14 feet.

⁶The 8¹/₄-inch thick roof panels, subject to concentrated roof maintenance live loads must be limited to a maximum span of 18 feet.

TABLE 5—ALLOWABLE UNIFORM TRANSVERSE LOADS FOR END SUPPORTED PANELS WITH DIMENSIONAL LUMBER SPLINES (psf)^{1,2,3}

THICKNESS (inches)		DEFLECTION LIMITS	PANEL SPAN (feet)												
Panel	Core		8	9	10	11	12	13	14	15	16	17	18	19	20
4 ¹ / ₂	3 ⁵ / ₈	L/180	46	41	37	33	31	28	23	—	—	—	—	—	—
		L/240	46	41	37	30	25	21	17	—	—	—	—	—	—
		L/360	38	30	25	20	16	14	12	—	—	—	—	—	—
6 ¹ / ₂	5 ⁵ / ₈	L/180	45	40	36	33	30	28	26	24	23	21	20	19	18
		L/240	45	40	36	33	30	28	26	24	23	21	20	18	16
		L/360	45	40	36	33	29	25	22	19	17	15	13	12	11
8 ¹ / ₄	7 ³ / ₈	L/180	44	39	35	32	29	27	25	24	22	21	20	19	18
		L/240	44	39	35	32	29	27	25	24	22	21	20	19	18
		L/360	44	39	35	32	29	27	25	24	22	21	20	18	16
10 ¹ / ₄	9 ³ / ₈	L/180	43	38	35	31	29	27	25	23	22	20	19	18	17
		L/240	43	38	35	31	29	27	25	23	22	20	19	18	17
		L/360	43	38	35	31	29	27	25	23	22	20	19	18	17

For **SI**: 1 inch = 25.4 mm, 1 foot = 304.8 mm, 1 psf = 47.9 Pa.

¹The tabulated values are for panels with single span simply supported conditions, with the panels supported each end by lumber plates installed in the core recesses each end of the panel, such as wall panels. The design of the lumber plate connection to the structure must be justified to the satisfaction of the code official.

²The tabulated values are applicable to panels installed with the strong axis of the OSB panel facer parallel to the panel span, and with the dimensional lumber splines described in Section 3.2.4 installed at 4 feet on center, parallel to the panel span. The 2 x 4 and 2 x 6 splines must be No. 2 spruce-pine-fir, or better, and the 2 x 8 and 2 x 10 splines must be No. 2 hem fir, or better. The OSB panel facers must be attached to the splines and the lumber end plates as described in Section 4.2.1.

³Values printed in italics are based on average peak loads divided by 3.

TABLE 6—ALLOWABLE UNIFORM AXIAL LOADS FOR WALL PANELS WITH INSULSPLINES OR OSB SURFACE SPLINES (plf)^{1,2,3,4,5}

THICKNESS (inches)		WALL PANEL HEIGHT (feet)										
Panel	Core	8	9	10	11	12	13	14	15	16	17	18
4 ¹ / ₂	3 ⁵ / ₈	2865	2728	2592	2455	2318	—	—	—	—	—	—
6 ¹ / ₂	5 ⁵ / ₈	2765	2755	2745	2735	2725	2714	2704	2694	2684	2674	2664
8 ¹ / ₄	7 ³ / ₈	2678	2664	2651	2637	2623	2610	2596	2582	2568	2555	2541
10 ¹ / ₄	9 ³ / ₈	2578	2560	2543	2525	2507	2490	2472	2454	2436	2419	2401

For **SI**: 1 inch = 25.4 mm, 1 foot = 304.8 mm, 1 plf = 14.6 N/m.

¹The tabulated loads are uniform axial loads applied concentrically to the full thickness of the panels, including panel facings.

²The tabulated values are for panels installed with the strong axis of the OSB panel facers parallel to the wall height (panel span).

³The tabulated values are for wall panels installed with a dimensional lumber top plate recessed into the core of the panel and a 2 x nominal lumber cap plate having a width equal to, or greater than, the panel thickness. The lumber must be No. 2 spruce-pine-fir, or better, for 2 x 4 and 2 x 6 plates, and No. 2 hem-fir, or better, for larger lumber sizes.

⁴The tabulated values are for wall panels with a single dimensional lumber bottom plate recessed into the panel core, installed over minimum 3/4-inch thick wood structural-use panel sheathing installed over floor joints spaced at 16-inches on center, perpendicular to the wall panel. The tabulated values are also applicable to wall panels installed with a recessed dimensional lumber bottom plate, installed over a minimum 2 x nominal lumber sill plate having a width equal to, or greater than, the panel thickness.

⁵The OSB panel facers must be attached to the lumber end plates as described in Section 4.2.1.

TABLE 7—ALLOWABLE UNIFORM AXIAL LOADS FOR WALL PANELS WITH DIMENSIONAL LUMBER SPLINES (plf)^{1,2,3,4,5}

THICKNESS (inches)		WALL PANEL HEIGHT (feet)												
Panel	Core	8	9	10	11	12	13	14	15	16	17	18	19	20
4 ¹ / ₂	3 ⁵ / ₈	2321	2260	2200	2139	2078	2018	1957	—	—	—	—	—	—
6 ¹ / ₂	5 ⁵ / ₈	2508	2566	2624	2681	2739	2797	2855	2912	2970	3028	3086	3143	3201
8 ¹ / ₄	7 ³ / ₈	2672	2696	2720	2745	2769	2793	2817	2841	2865	2890	2914	2938	2962
10 ¹ / ₄	9 ³ / ₈	2672	2696	2720	2745	2769	2793	2817	2841	2865	2890	2914	2938	2866

For **SI**: 1 inch = 25.4 mm, 1 foot = 304.8 mm, 1 plf = 14.6 N/m.

- ¹The tabulated loads are uniform axial loads applied concentrically to the full thickness of the panels, including panel facings.
- ²The tabulated values are for panels installed with the strong axis of the OSB panel facers parallel to the wall height (panel span) and with the dimensional lumber splines described in Section 3.2.4 installed at 4 feet on center.
- ³The tabulated values are for wall panels installed with a dimensional lumber top plate recessed into the core of the panel and a 2 x nominal lumber cap plate having a width equal to, or greater than, the panel thickness. The lumber must be No. 2 spruce-pine-fir, or better, for 2 x 4 and 2 x 6 plates, and No. 2 hem-fir, or better, for larger lumber sizes.
- ⁴The tabulated values are for wall panels with a single dimensional lumber bottom plate recessed into the panel core, installed over minimum 3/4-inch thick wood structural-use panel sheathing installed over floor joists spaced at 16-inches on center, perpendicular to the wall panel. The tabulated values are also applicable to wall panels installed with a recessed dimensional lumber bottom plate, installed over a minimum 2 x nominal lumber sill plate having a width equal to, or greater than, the panel thickness.
- ⁵The OSB panel facers must be attached to the lumber end plates as described in Section 4.2.1.

TABLE 8—ALLOWABLE CONCENTRATED AXIAL LOADS FOR WALL PANELS WITH INSULSPLINES OR OSB SURFACE SPLINES (lb spaced at 2 feet on center)^{1,2,3,4,5}

THICKNESS (inches)		WALL PANEL HEIGHT (feet)
Panel	Core	8
4 ¹ / ₂	3 ⁵ / ₈	4445
6 ¹ / ₂	5 ⁵ / ₈	4414
8 ¹ / ₄	7 ³ / ₈	4387
10 ¹ / ₄	9 ³ / ₈	4356

For **SI**: 1 inch = 25.4 mm, 1 foot = 304.8 mm, 1 plf = 14.6 N/m.

- ¹The tabulated loads are concentrated axial loads spaced at 24 inches on center and applied concentrically to the full thickness of the panels, including panel facings.
- ²The tabulated values are for panels installed with the strong axis of the OSB panel facers parallel or perpendicular to the wall height (panel span).
- ³The tabulated values are for wall panels installed with a dimensional lumber top plate recessed into the core of the panel and a 2 x nominal lumber cap plate having a width equal to, or greater than, the panel thickness. The lumber must be No. 2 spruce-pine-fir, or better, for 2 x 4 and 2 x 6 plates, and No. 2 hem-fir, or better, for larger lumber sizes.
- ⁴The tabulated values are for wall panels with a single dimensional lumber bottom plate recessed into the panel core, installed over minimum 3/4-inch thick wood structural-use panel sheathing installed over floor joists at 16-inches on center, perpendicular to the wall panel. The tabulated values are also applicable to wall panels installed with a recessed dimensional lumber bottom plate, installed over a minimum 2 x nominal lumber sill plate having a width equal to, or greater than, the panel thickness.
- ⁵The OSB panel facers must be attached to the lumber end plates as described in Section 4.2.1.

TABLE 9—ALLOWABLE RACKING SHEAR LOADS FOR 4.5-INCH THICK WALL PANELS (plf)^{1,2,3,4,5,6,7,8}

INSTALLATION CONFIGURATION	VERTICAL SPLINE TYPE	INSET BOTTOM PLATES	INSET TOP PLATES	END POSTS	NAIL SPACING (inches)	ALLOWABLE SHEAR LOADS (plf)
A ⁸	OSB Surface Splines	Single 2 x 4	Double 2 x 4	Double 2 x 4	6	366
B ⁹	OSB Surface Splines	Single 2 x 4	Double 2 x 4	Double 2 x 4	3	557
C ⁸	Double 2 x 4	Single 2 x 4	Double 2 x 4	Double 2 x 4	6	366
D ⁹	Double 2 x 4	Single 2 x 4	Double 2 x 4	Double 2 x 4	3	639

For **SI**: 1 inch = 25.4 mm, 1 plf = 14.6 N/m.

- ¹The panels must be installed with the strong axis of the OSB facers oriented vertically.
- ²The maximum shearwall height-to-length ratio is 1:1.
- ³The double top plates and double end posts must be nailed together with 10d box nails spaced at 4 inches on center in two staggered rows.
- ⁴The shearwall end posts must be full wall height.
- ⁵The dimensional lumber bottom plates, top plates and end posts must be No. 2 spruce-pine-fir, or better.
- ⁶The OSB surface splines must be as described in Section 3.2.4.
- ⁷The nails used to attach the OSB facers of the panels to the bottom plates, top plates and end posts must be 8d box nails spaced a minimum of ³/₄-inch from the edges and ends of the sandwich panels. The nails must have a minimum bending yield strength, F_{yb}, of 100 ksi (689 kPa).
- ⁸Installation Configuration A and C are recognized for use as shearwalls in Seismic Design Categories A through C. Installation Configurations A and C, installed and supported directly by a concrete foundation, are also recognized for use as shearwalls in Seismic Design Categories D through F, provided the walls are nonload-bearing walls. For use of installation Configuration C as a load-bearing wall and a shearwall in Seismic Design Categories D, E or F, see additional requirements noted in Section 4.1.
- ⁹The shearwalls are recognized for use in Seismic Design Categories A, B and C only.

TABLE 10—ALLOWABLE RACKING SHEAR LOADS FOR 6.5-INCH THICK WALL PANELS (plf)^{1,2,3,4,5,6,7,8,9,10}

INSTALLATION CONFIGURATION	VERTICAL SPLINE TYPE	INSET BOTTOM PLATES	INSET TOP PLATES	END POSTS	NAIL SPACING	ALLOWABLE SHEAR LOADS (plf)
A ¹¹	Insulspline	Single 2 x 6	Double 2 x 6	Double 2 x 6	6 ⁸	349
B ¹¹	Double 2 x 6	Single 2 x 6	Double 2 x 6	Double 2 x 6	6 ⁸	394
C ¹²	Single 4 x 6	Single 4 x 6	Single 4 x 6	Single 4 x 6	4 ⁸	591
D ¹²	Single 4 x 6	Single 4 x 6	Single 4 x 6	Single 4 x 6	2 ⁹	881

For **SI**: 1 inch = 25.4 mm, 1 plf = 14.6 N/m.

- ¹The panels must be installed with the strong axis of the OSB facers oriented vertically.
- ²The maximum shearwall height-to-length ratio is 1:1.
- ³The double top plates and double end posts must be nailed together with 10d box nails spaced at 8 inches on center in two staggered rows.
- ⁴The shearwall end posts must be full wall height.
- ⁵The dimensional lumber bottom plates, top plates and end posts must be No. 2 Douglas fir-larch, or better.
- ⁶The Insulsplines must be as described in Section 3.2.4.
- ⁷The nails used to attach the OSB facers of the panels to the bottom plates, top plates and end posts must be 8d box nails, having a minimum bending yield strength, F_{yb}, of 100 ksi (689 kPa).
- ⁸For OSB nail spacings of 4 and 6-inches, the rows of nails must be ³/₄-inch from the edges and ends of the sandwich panels.
- ⁹For OSB nail spacing of 2 inches, the nails must be installed in two rows (4 inches on center in each row). For nails installed into the shearwall perimeter (top plate, bottom plate and end posts), the first row of nails must be ³/₄-inch from the sandwich panel edges and the second row of nails must be 1 ¹/₂ inches from the first row. For nails installed into the vertical splines, the first row of nails must be ⁵/₈-inch from the sandwich panel edge and the second row of nails must be 1 ¹/₈ inches from the first row.
- ¹⁰Each 2 x 6 member of the double end posts and vertical spline must be fastened to the top and bottom plates with 3—10d box end nails. Each 4 x 6 end post and spline must be attached to the top and bottom plates with 4-10d box toenails.
- ¹¹Installation Configurations A and B are recognized for use as shearwalls in Seismic Design Categories A through C. Installation Configurations A and B, installed and supported directly by a concrete foundation, are also recognized for use as shearwalls in Seismic Design Categories D through F, provided the walls are nonload-bearing walls. For use of installation Configuration B as a load-bearing wall and a shearwall in Seismic Design Categories D, E or F, see additional requirements noted in Section 4.1.
- ¹²The shearwalls are recognized for use in Seismic Design Categories A, B and C only.

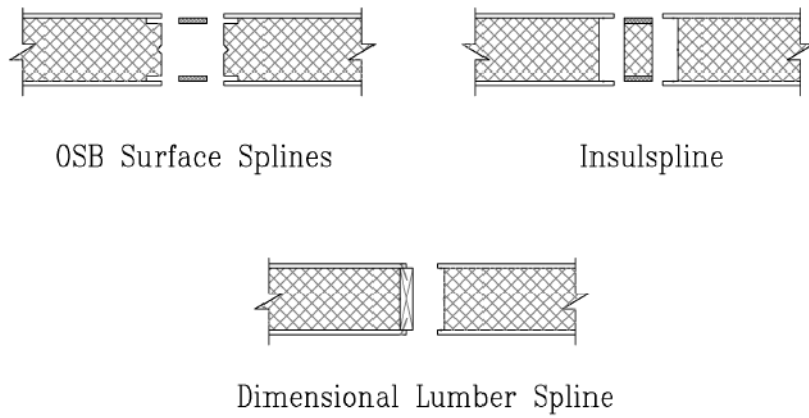

FIGURE 1—TYPE OF LONGITUDINAL SPLINES

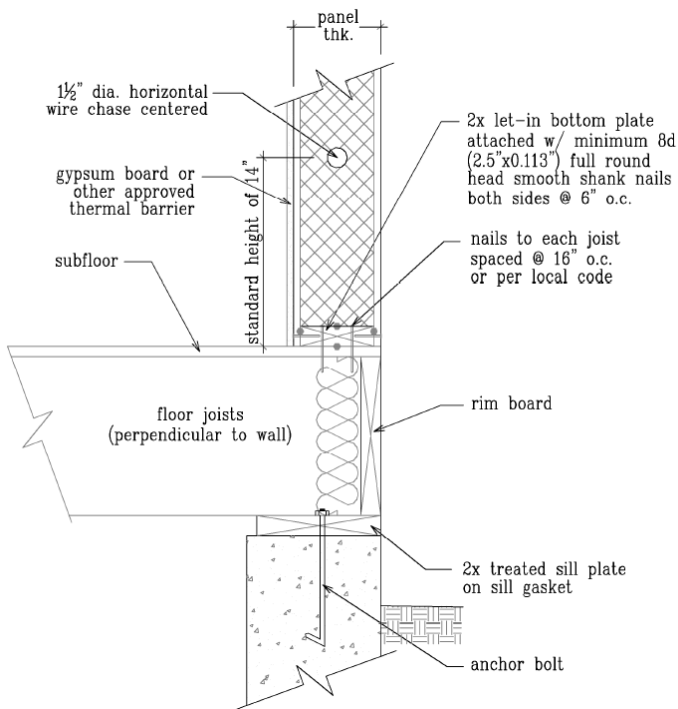

FIGURE 2—TYPICAL WALL PANEL ON FLOOR

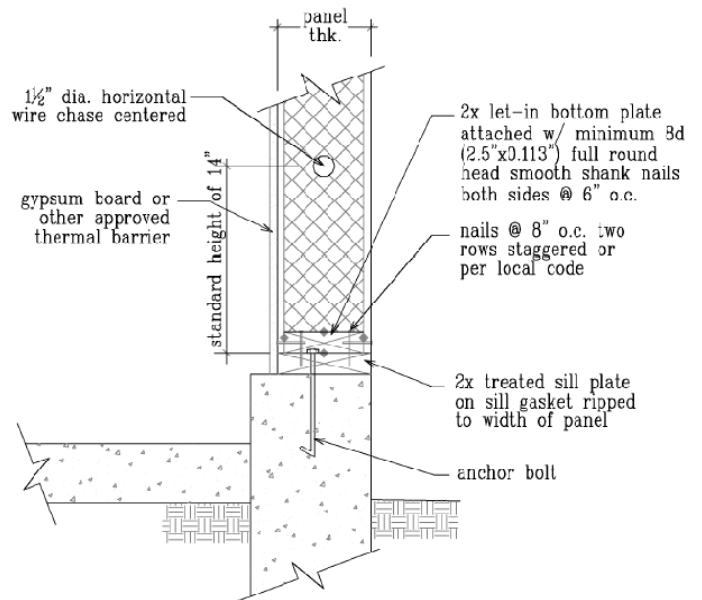

FIGURE 3—TYPICAL WALL PANEL ON FOUNDATION

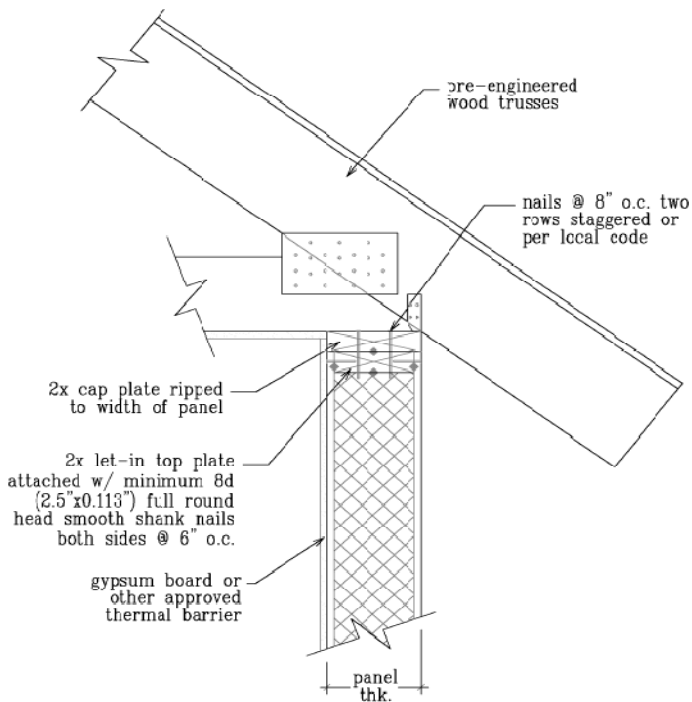

FIGURE 4—TYPICAL ROOF TRUSS TO WALL PANEL

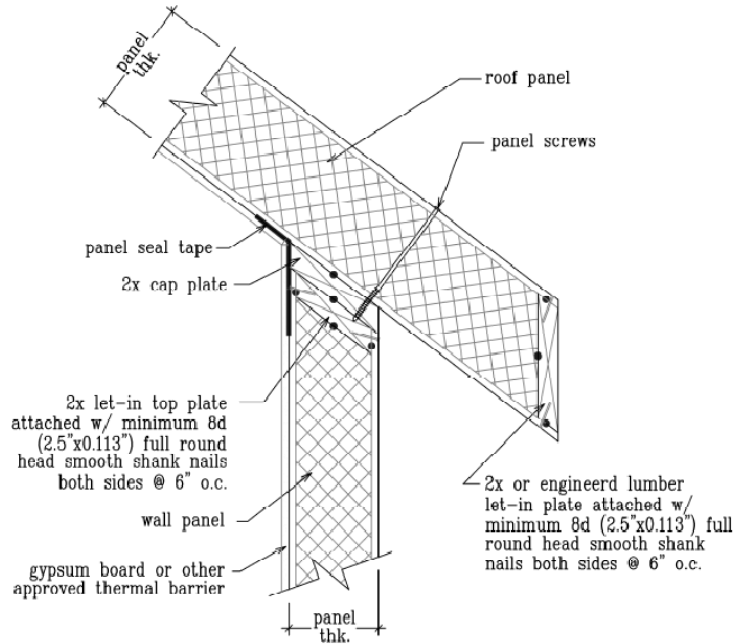

FIGURE 5—WALL PANEL TO ROOF PANEL WITH BEVELED TOP PLATE

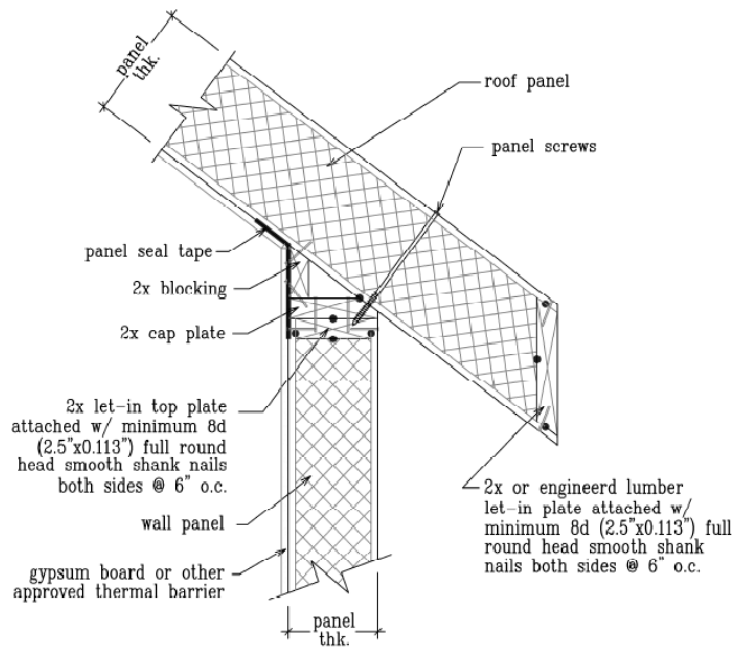

FIGURE 6—WALL PANEL TO ROOF PANEL WITH 2X BLOCKING

ICC-ES Evaluation Report**ESR-1295 Supplement**

Issued February 1, 2011

This report is subject to re-examination in two years.www.icc-es.org | (800) 423-6587 | (562) 699-0543

A Subsidiary of the International Code Council®

DIVISION: 06 00 00—WOOD, PLASTICS AND COMPOSITES
Section: 06 12 00—Structural Panels**REPORT HOLDER:****INSULSPAN INCORPORATED**
100, 2886 SUNRIDGE WAY NE
CALGARY, ALBERTA T1Y 7H9
CANADA
www.insulspan.com
jwhalen@insulspan.com**EVALUATION SUBJECT:****INSULSPAN STRUCTURAL INSULATING PANEL SYSTEM****1.0 EVALUATION SCOPE****Compliance with the following codes:**

- 2007 Florida Building Code—Building
- 2007 Florida Building Code—Residential

Property Evaluated:

- Structural
- Fire Resistance

2.0 PURPOSE OF THIS SUPPLEMENT

This supplement is issued to indicate that the Insulspan Structural Insulating Panel System described in Sections 2.0 through 7.0 of the master report comply with the 2007 Florida Building Code—Building and the 2007 Florida Building Code—Residential, when designed and installed in accordance with the master evaluation report.

Use of the Insulspan Structural Insulating Panel System described in the master evaluation report for compliance with the High-Velocity Hurricane Zone provisions of the 2007 Florida Building Code—Building and the 2007 Florida Building Code—Residential has not been evaluated, and is outside the scope of this supplement.

For products falling under Florida Rule 9B-72, verification that the report holder's quality assurance program is audited by a quality assurance entity approved by the Florida Building Commission for the type of inspections being conducted is the responsibility of an approved validation entity (or the code official when the report holder does not possess an approval by the Commission).

This supplement expires concurrently with the master report reissued February 1, 2011.